

Low Cost Primary Referenced Green-mode PWM Controller and Special Purpose Family MPS-888-CA/CG/CH

FEATURES

- PWM Controller suitable for DC-DC and off-line applications.
- Optional Output cable compensation
- Valley Switching for highest efficiency.
- High speed drive for loss-less turn off.
- Proprietary Feed forward loop.
- Low current start up typ 30uA.
- Up to 500 KHz operation.
- Enables designs to comply with CEC and Energy star Level V.
- Suitable for 2W – 24W Low Cost Adapters.
- Supports Primary or Secondary Regulation
- Consumer and Industrial Grade options
- Low cost proprietary miniature Bi-polar SOT23-6 package.
- VCC transient protection to 18V.
- Proprietary Topology enables dramatic transformer size and cost reduction of up to 40% or more.
- Full Design Support for 3 Sigma Production ready designs

APPLICATIONS

- Off-line power supplies.
- Internet Appliances
- Motherboard Bias Supplies
- Battery chargers.
- Linear transformer replacements.
- LED lighting current sources.
- DC-DC converters and Standby SMPS.
- Complete Single Range or Universal Input Wall and Desktop adapters.
- Travel adapters.
- Industrial Appliances
- Automotive DC-DC converters
- EV, Solar and Wind converters

DESCRIPTION

MPS88 is a universal application low cost green controller for AC-DC and DC-DC converters supporting applications from 18V-700V inputs. These converters are often employed in Primary or Secondary regulated Single Range or Universal Input Off-line Switch Mode Power Supplies. It also enables compliance with CEC and Level V Energy Star 2008 Standards Encapsulated in a miniature SOT23-6 package, MPS88 represents a significant advancement for PWM controllers, enabling Green, ultra-compact, very efficient, and low cost switch mode power supplies (SMPS) when employed within the novel MPS fly- back patent pending topology.

When buffered the controller is suitable for use within primary or secondary regulated single range or universal input off-line switch mode power supplies up to 300W. When incorporated in the MPS proprietary Fly-back Switching topology, it provides many significant advantages over competing technologies. In short, the device provides the lowest manufacturing costs, highest average operating efficiencies under all operating conditions, in the smallest open frame or enclosed configurations over applications requiring 2-12 watts of power for Universal Input and 2-24 watts of power for Geographical AC input requirements.

This smart and flexible low cost high speed PWM controller employs two co-dependent feed-back loops that simultaneously adjust both the on and off time of the controller in order to minimize losses in the converter. With the appropriate topology design, the converter locks in the optimal operating conditions to set up the average efficiencies of greater than 85%, even in demanding high temperature full range 80 to 270 VAC Universal off-line applications are readily achievable.

This enabling topology facilitates volume manufacturing cost reductions of up to 25% for AC/DC Wall adapters, while providing operating efficiencies, up to 85% or higher to exceed the latest agency Energy Star Level V and CEC guidelines

Typical Application Primary Referenced MPS888CG

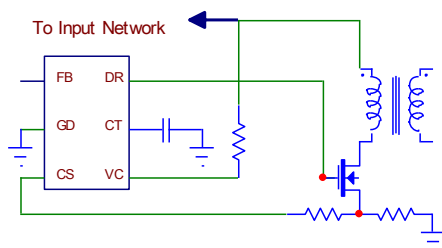

Typical Application Secondary Referenced MPS888CH

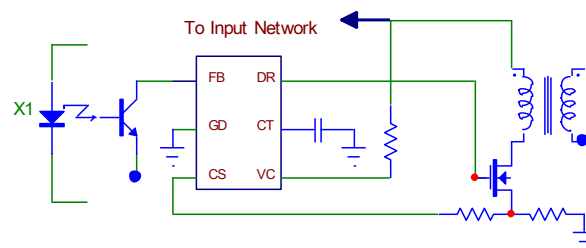

**Low Cost Primary Referenced Green-mode PWM Controller and Special Purpose Family
MPS-888-CA/CG/CH**

PIN No.	Symbol	Function	Description
1	FB	Feedback	FB reference voltage from primary or secondary voltage source.
2	GND	Ground	IC Paddle ground reference pin.
3	CS	Current sense	The CS pin senses the power switch current.
4	VCC	Input Voltage	VCC supply to chip.
5	CT	Timing Capacitor	Sets discharge time.
6	DR	Driver Output	Drive pin to MOS-FET Gate.

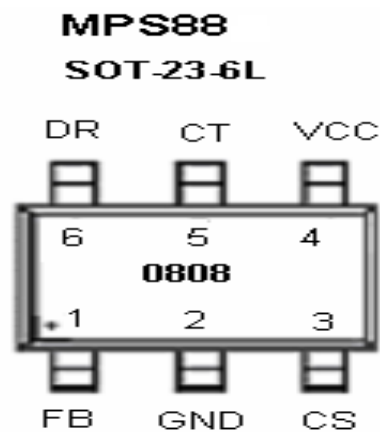

Low Cost Primary Referenced Green-mode PWM Controller and Special Purpose Family MPS-88-CA/CG/CH

INTERNAL BLOCK DIAGRAM

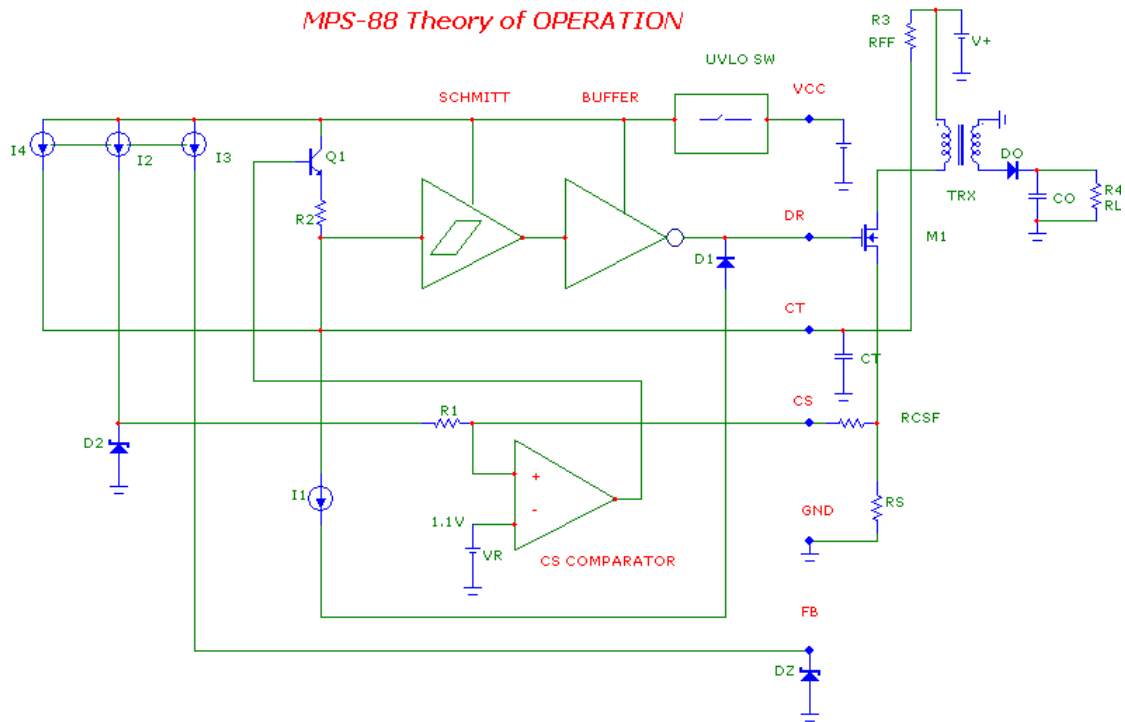

Sequence of Events

1. As Pin 6 of the MPS 88 the DR Pin goes high the current flowing through M1 MOSFET source resistor RS starts ramping up, is sensed and fed via RCSF to the CS comparator.
2. At the moment the voltage drop on RS exceeds 1V the output of the Current sense Comparator will pull the CT pin above the high set threshold point, which is set to 2/3 or 66.6% of VCC.
3. At this point DR begins to go low and the current I1 will start discharging the CT capacitor.
4. CT discharges until the lower threshold which is set to (1/3 VCC) or 33% of VCC at which point the DR begins to go high again and the cycle repeats itself.
5. Primary side Vz sets the VCC voltage, which in turn defines the output voltage by changing both the on time and the off time.
6. D2 ZENER diode together with R1 and RCSF will set the lowest limit ON TIME as well as the ON and OFF time ratio's for a given feedback condition.
7. R2 together with CT forms a low pass filter to attenuate noise from the current sense sample.
8. The delay introduced by R2, CT capacitor and the CS comparator allows the frequency to be shifted lower at high line by the RFF (feed-forward resistor).

Low Cost Primary Referenced Green-mode PWM Controller and Special Purpose Family MPS-888-CA/CG/CH

MAXIMUM RATINGS

Rating	Symbol	Value	Unit
Supply Voltage	V cc	18	V
FB voltage	V fb	17.4	V
CS pin Voltage	V cs	1.5	V
CT pin voltage	V ct	11.88	V
Max Junction Temperature	TJ	150	°C
Storage Temperature	T stg	120	°C

- **Maximum ratings** are those values beyond which device damage can occur.

ELECTRICAL CHARACTERISTICS

(Vcc=12V, for typical values Tj = 25 °C, for min/Max values Tj = 0 °C to +100 °C, unless otherwise noted.)

VOLTAGE FEEDBACK:

CHARACTERISTICS	Symbol	Min	Typ.	Max	Unit
FB-VCC Voltage	Vfb	0.6	0.7	0.8	V
CT pin Voltage at FB Current = 25µA	VCT-25µA	0.8	1	1.4	V
CT pin Voltage at FB Current = 50µA (Including V offset)	VCT-50µA	0.8	1	1.6	V
MPS 88G Internal 5% Reference	FB REF	13	13.2	13.5	V

CT PIN-OFF TIME CONTROL:

CHARACTERISTICS	Symbol	Min	Typ.	Max	Unit
Discharge Current	ICT	180	220	260	µA
CT Noise Filter Delay	TDCT	-	0.09	-	µS
Schmitt Lower Threshold (VCC/3)	VSCHL	-	4.1	-	V
Schmitt Higher Threshold (2*VCC/3)	VSCHH	-	8.1	-	V

CURRENT SENSE:

CHARACTERISTICS	Symbol	Min	Typ.	Max	Unit
CS at FB maximum	ICSFb	-	120	-	µA
Comparator threshold Voltage	VCSTRH	1	1.1	1.2	V
CS Propagation Delay Time	TCSDEL	-	250	450	ns

GATE DRIVE:

CHARACTERISTICS	Symbol	Min	Typ.	Max	Unit
Sink Current A* / GH	ROL	35*/50	50*/80	70*/100	mA
Source Current	ROH	-	20*/30	-	mA
On Delay Time	TONDEL	-	0.1	-	µS

POWER SUPPLY:

CHARACTERISTICS	Symbol	Min	Typ.	Max	Unit
VCC Startup	VST	12.4	12.6V	12.9	V

**Low Cost Primary Referenced Green-mode PWM Controller and Special Purpose Family
MPS-888-CA/CG/CH**

VCC Startup Lockout Threshold Voltage	V startup	8.0	8.5	9.0	V
Internal Startup Current Consumption	ICC-start	-	35	50	uA
Operating current (load=100 pF, f = 100 kHz)	ICO	4.5	5.5	6.5	mA

Output:

CHARACTERISTICS	Symbol	Min	Typ.	Max	Unit
Rising time 100pf load	tr	-	100	-	ns
Falling time 100pf load	tf	-	25	-	ns

MPS88 APPLICATION NOTE:**1. START UP**

The start up current -typically 35ua enables the use of start up resistor in the MEGOHM range in order to minimize light load efficiency and standby power consumption. Once the voltage on the VCC reaches its start up threshold -typically 12.6V, then the controller will be enabled and the current will start rising in the transformers primary.

2. CURRENT SENSE AND ON TIME

The primary current through the current sense resistor will activate the current sense comparator -1.1v typical - and the ON time will be terminated. The on time interval is determined by the expression-
 $T_{ON} = V * LP / IPK$

3. OFF TIME

The peak current mode control would be increasing the frequency as the input voltage increases and this in turn would increase overload current. To avoid over designing to handle overload a feed forward current is used to compensate for the frequency increase which is proportional to the input voltage. This additional current is simply applied via an external RFF resistor applied to the Ct pin.

The OFF time will be defined by the value of the CT capacitor, the comparator hysteresis, the feed forward and the discharge current. The off time interval is expressed by $TOFF = C * VHYST (/IDCH-IFF-IFB)$

4. FEEDBACK

Primary load cable compensation and precision output voltage regulation may be facilitated. As the line and load varies both the ON time and the OFF time is modified to regulate the output voltage. For low cost linear replacements simply the 888 G series is recommended. Where precision output voltage is desired simply by adding an external zener and RC compensation network or precision reference to the H IC series on the feedback pin thereby enables the VCC voltage to be referenced for the Fb voltage to be regulated and in turn the output voltage will remain within +/- 5% from 1% to 100 % load changes with the MPS recommended TRX design.

5. FEEDFORWARD AND CURRENT SENSE DELAY COMPENSATION

The unique feature of the topology is the predetermined amount of delay built into the current sense allowing the ratio of low line to high line current peak to be selected and in turn the amount of frequency change to achieve lower switching losses at high line and lower conduction losses at low line- the result is a nearly flat line of full load efficiency versus input line voltage for a 4 to 1 input voltage range with minimum overload stress on the power devices.

Optimal designs operate in CCM for North American line voltages (120V) and automatically switch to DCM for European voltages (240V) with the current peak ratio as set by a delay compensation resistor to inject a

**Low Cost Primary Referenced Green-mode PWM Controller and Special Purpose Family
MPS-888-CA/CG/CH**

small feed forward current to the cs pin proportional to the supply voltage. Typically a current peak ratio of 1.1 is used from high line to low line reducing EMI and losses at the extremes of the input line voltage.

REFERENCE CIRCUIT FOR PRIMARY REGULATION O/P V +/- 5% from 5%-100% load

High Performance Low Cost 90-264VAC Input Linear Adapter 12V 7 watt output Level V Efficiency

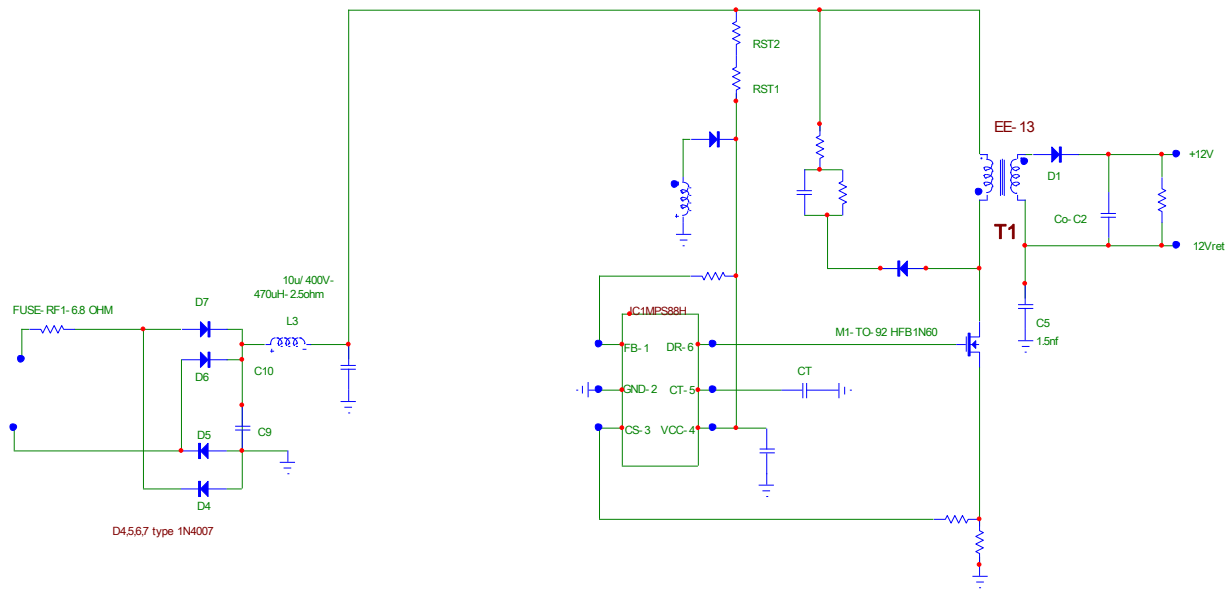

12V 7W Output Transient Response

12V 7W Valley Switching Waveform

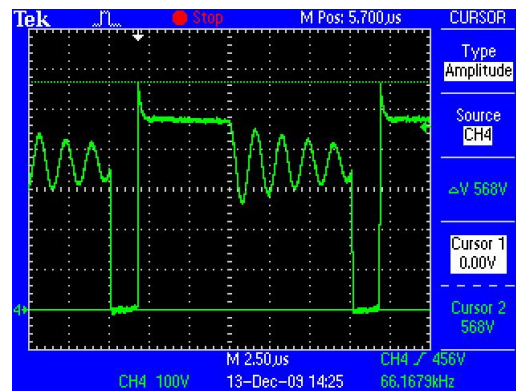
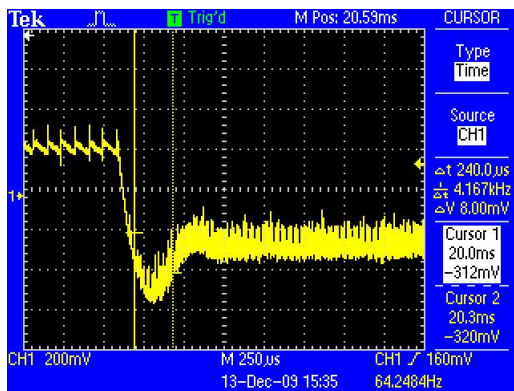

**Low Cost Primary Referenced Green-mode PWM Controller and Special Purpose Family
MPS-888-CA/CG/CH**

High Performance Precision CONSTANT VOLTAGE CONSTANT CURRENT DC-DC and LED Driver

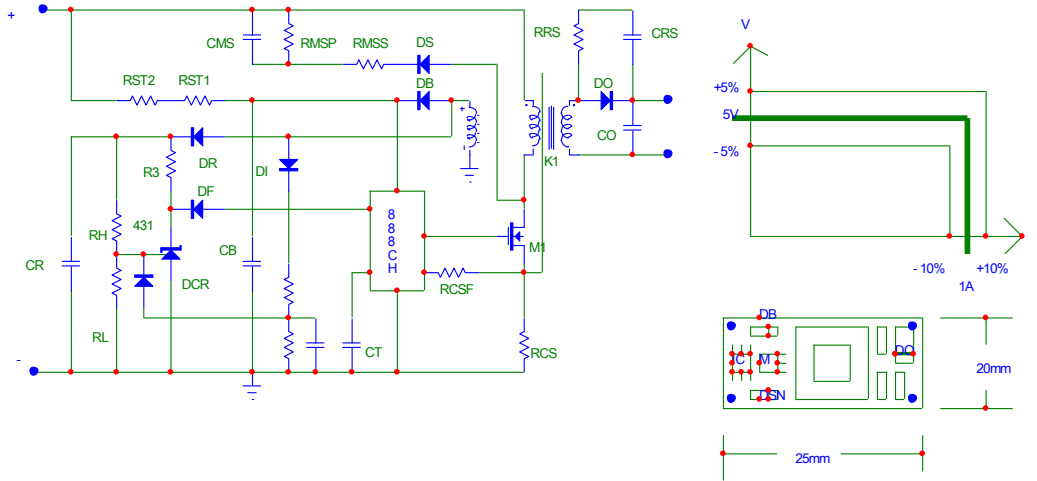

High Power Factor (>0.9) LED Driver

Low Noise MOSFET Drain Scope waveform illustrating Valley Switching @ 400VDC

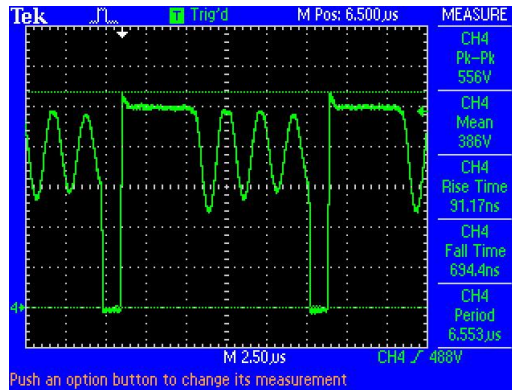

Low Cost Primary Referenced Green-mode PWM Controller and Special Purpose Family
MPS-888-CA/CG/CH

Additional MPS88 CG /CH Applications

1 DECADE VCO- 1MHZ

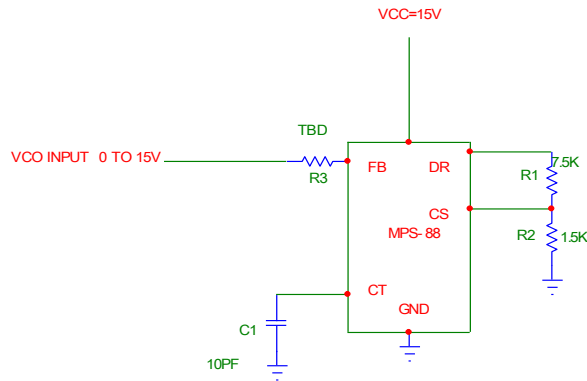

NOTE - R3 IS THE VCO GAIN SETTING - SEE APPL NOTE

5MHZ- 50%DUTY OSCILLATOR

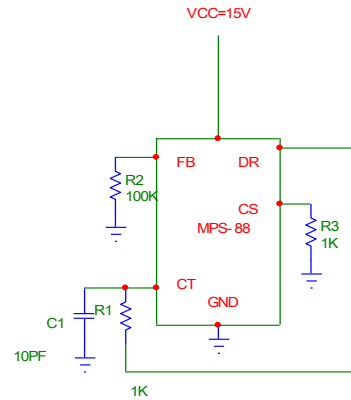

APPLICATION 2

Low Cost Gate drive Buffer

200ma buffer with 2N3906 and 2N3904

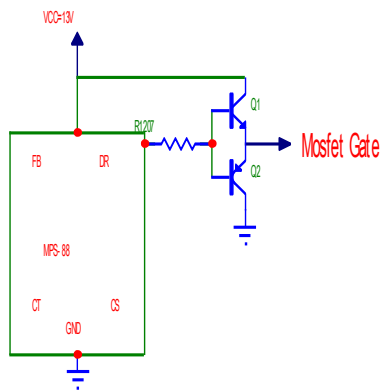

High Current Gate Drive Buffer

10A buffer with Diodes Inc ZXGD3001

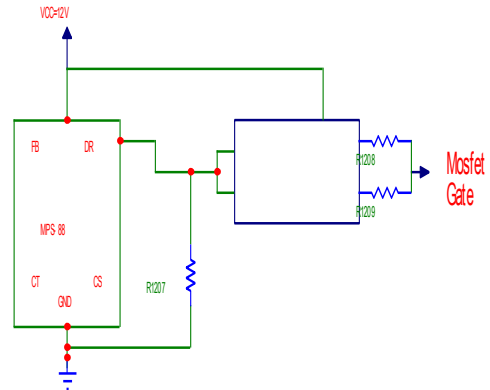

Low Cost Primary Referenced Green-mode PWM Controller and Special Purpose Family
MPS-888-CA/CG/CH

PACKAGE INFORMATION

PIN CONFIGURATION

Package Outline Dimensions (SOT23-6)

DIM	MILLIMETERS	
	MIN	MAX
A	2.90	3.10
B	1.30	1.70
D	0.25	0.50
G	0.85	1.05
L	1.25	1.55
S	2.50	3.00

MPS88

SOT-23-6L

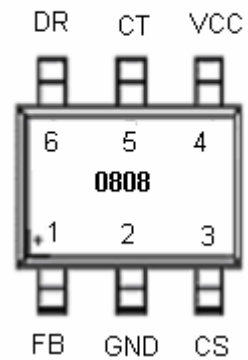

PCB Soldering Footprint

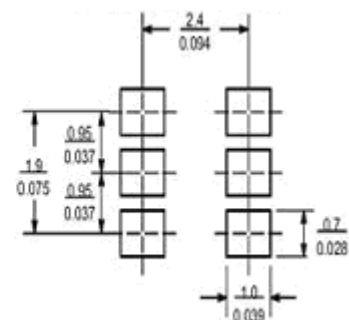
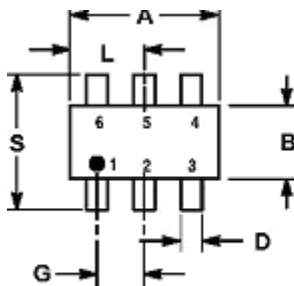

**Low Cost Primary Referenced Green-mode PWM Controller and Special Purpose Family
MPS-888-CA/CG/CH**

DISCLAIMERS

All the specifications are subject to change without prior notice.